

# **Design for MOSIS Educational Program (Research)**

**BBIC #1: T3CW-AH**

## **Project Title**

**Low-Power Bioluminescent Bioreporter Integrated Circuit  
(BBIC) in CMOS Technology**

**Prepared by:** S.C. Terry, N. Islam, Mo Zhang, S.K. Islam, and B.J. Blalock

**Institution:** Department of Electrical and Computer Engineering, University of  
Tennessee, Knoxville, TN-37996-2100

## Introduction:

Biosensors are hybrid devices combining a biological sensing component with an analytical measuring element. The biological component typically reacts and/or interacts with an analyte of interest to produce a response that can be quantified by an electronic, optical or mechanical transducer. The most common configuration uses immobilized macromolecules such as enzymes or antibodies as the biological component; another, less common, approach uses living microorganisms or sections of organs or tissues as the biological element. These biosensors otherwise known as the whole-cell biosensors are particularly well suited to environmental sensing because they are small enough to be carried in the field and are capable of continuous monitoring. These sensors can be used to detect herbicides, alcohol, benzyne, oxygen etc. The proposed whole cell sensors are genetically engineered bioreporters that produce bioluminescence when in contact with a targeted substance. The proposed work involves analysis, design, fabrication and testing of the microluminometer for use in electronic/biological chemical sensor known as Bioluminescent Bioreporter Integrated Circuit (BBIC). The bioreporters are placed on a CMOS integrated circuit (IC) that detects bioluminescence, performs signal processing, and transmits the sensor data to a remote location. The basic building blocks of the integrated circuit are the microluminometer and the transmitter. The microluminometer includes integrated photodetector and signal processor and the transmitter performs wireless data transmission. The BBIC is housed in a rugged inexpensive package as shown in Figure 1 and can be used in many remote applications in hazardous environment. The close proximity of the bioreporter and the sensing element eliminates need for complex instrumentation to channel light from the bioreporters to the microluminometer. In addition, the integrated wireless feature of the system will allow remote sensing without need for bulky and costly cables to communicate with the sensors. Thus the BBIC provides a low-power, inexpensive, selective and highly sensitive biosensor.

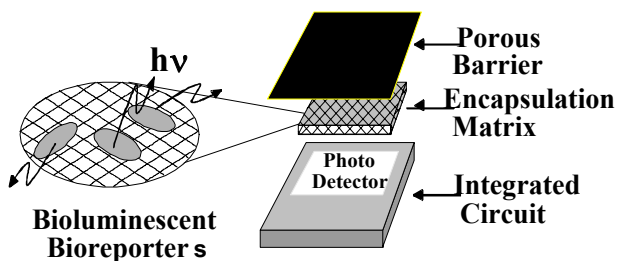
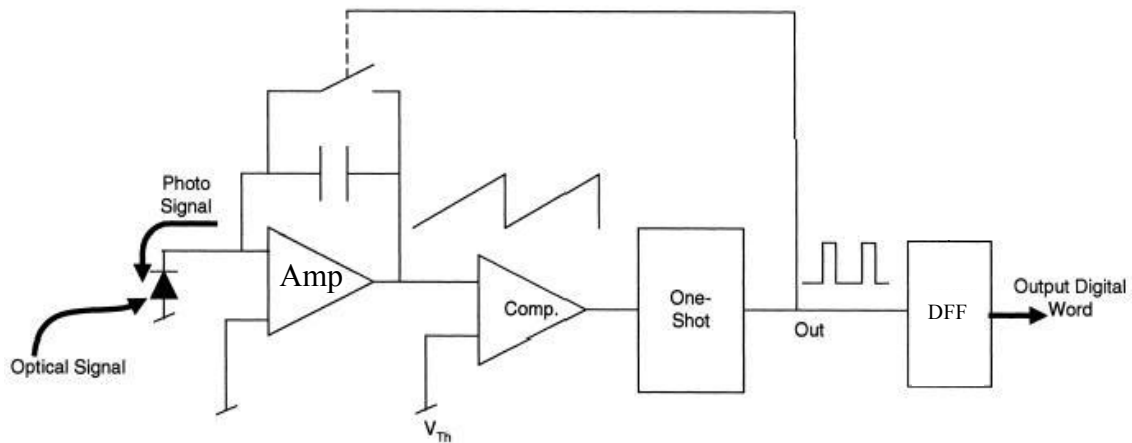

**Fig 1:** Conceptual BBIC system showing the immobilized bioreporter inserted between a porous layer and the integrated circuit with a photodetector.

## Project Description:

The basic operation of the microluminometer includes photodetection and analog-to-digital transmission. The following is the basic principle of operation of this device. The genetically engineered bioreporters produce bioluminescence when in contact with a targeted substance. The amount of light generated by bioluminescence is proportional to the concentration of the analyte of interest. Then the bioluminescence is absorbed by a photodiode in the device. Electrical current is created in the diode, which is proportional

to the density of light. Then the electrical current is converted to a digital signal by an analog-to-frequency converter circuit as shown in figure 2.



**Fig 2:** Circuit diagram of the BBIC chip

Figure.2 is the circuit diagram of BBIC chip. The photodiode and analog, digital elements are all placed on a CMOS integrated circuit, which can both detects bioluminescence and performs signal processing. This design focuses on low-power circuits while maintaining low-noise performance.

Methods to resolve the problem have been found through nearly one year's of research work. A number of small resistors were initially used in the design for but simulation showed large currents between the power supply ( $V_{DD}$ ) and ground. These were then replaced by transistors, which are designed to be in the saturation region of operation. This design modification reduced the currents in amplifiers without affecting the resetting time by much. The power consumption is reduced to about one tenth of the original one in the simulation. And the simulation shows good analog signal processing and digital output. But without making a real chip, the work may not be proved at all.

The chip was designed in TSMC 0.35 $\mu$ m process and the size of the chip was of the tiny chip format [2.25 sq mm (1.5mmx1.5mm)].

### **Design and Simulation:**

The initial design and simulation have been performed using Spectre. And the design has been laid out. In Cadence Design environment, a Design Rules Check (DRC) and a Layout Versus Schematics (LVS) have been performed to ensure that everything is in order. And post layout simulation has been carried out with an ideal current source instead of the on-chip photodiode, which may not be simulated in Cadence. And the simulation result is good as expected.

## Test & Characterization:

The chip has been tested using in the Analog VLSI and Devices Laboratory and the Center for Environmental Biotechnology (UTCEB) Laboratory at the University of Tennessee. Several test methods have been considered.

The new circuit reduced the power dissipation by a factor of three compared to previous design, because of inducing the low noise OTA design. The total power dissipation is only about 3.3mW. The off-chip biasing circuits are greatly simplified. No external resistors were required, which were necessary for previous versions of the BBIC circuit. On-chip beta multiplier current reference was included and DAC was provided to control the comparator's threshold voltage off-chip by simply connecting D0-D4 ports to  $V_{DD}$  or Ground voltage.

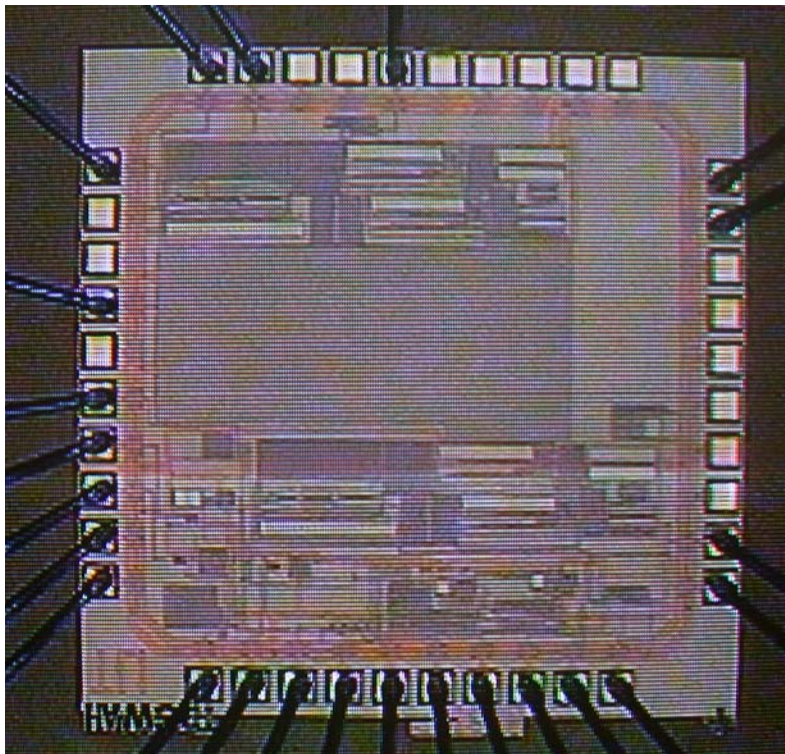

**Fig 3:** Optical image of fabricated chip (T3CW-AH)

T3CW-AH chip was designed for checking the function blocks separately. Figure 3 shows the test result of this chip.

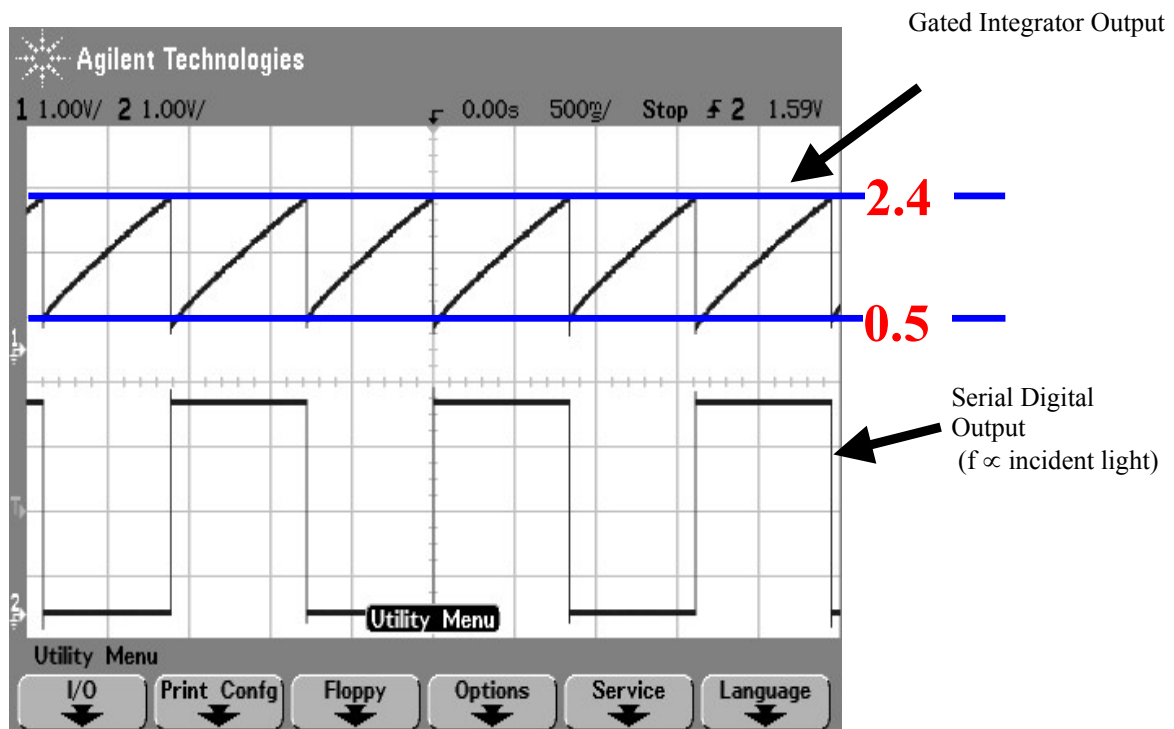

**Fig 4:** Test result of T3CW-AH chip

The integrating part works nicely, starting from 0.5V and reset at 2.4V. The DFF output was a square wave signal, whose increasing edge and falling edge corresponded to the integrators reset accurately.

## References:

- [1] M. L. Simpson, G.S. Sayler, S. Ripp, D.E. Nivens, B.M. Applegate, M.J. Paulus, and G.E. Jellison Jr. "Bioluminescent-Bioreporter Integrated Circuits Form Novel Whole-Cell Biosensor". Trends in Biotechnology, Vol.16, pp. 332-338, August 1998.
- [2] Simpson, M. L., G. S. Sayler, J. T. Fleming, and B. A. Applegate. "Whole-cell biocomputing: engineering the information processing functionality of cells". Trends in Biotechnology 19(8), August 2001, 317-323
- [3] Mo Zhang, "A Low Power Cmos Microluminometer And Transmitter For Bioluminescent Bioreporter Integrated Circuit (BBIC) ", Master thesis, April 2003
- [4] Simpson, M. L., G. S. Sayler, G. Patterson, D. Nivens, E. K. Bolton, J. M. Rochelle, J. C. Arnott, B. M. Applegate, S. Ripp, and M. A. Guillorn. "An integrated CMOS Microluminometer for low-level luminescence sensing in the bioluminescent bioreporter integrated circuit", Sens. and Act. B 72(2), Jan. 2001, 135-141.